

BALL VALVES INTEC

K411, DN15 - DN100, PN16/40
trunnion mounted ball, metal seated,
spring loaded seat rings

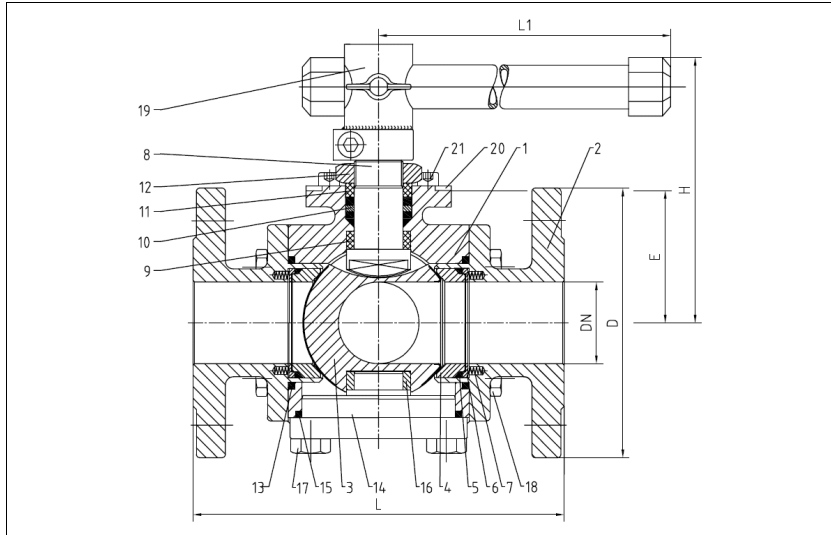

3-way ball valve with flanges
full bore
face to face acc. to EN 558, GR.1
flanges acc. to EN 1092







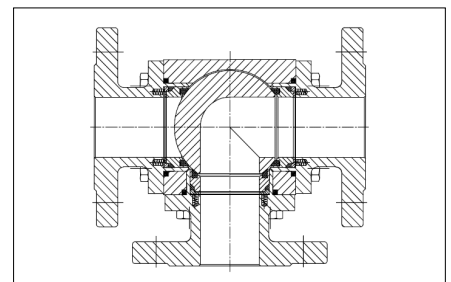

Specification:

3-way ball valve with flanges acc. to EN 1092, face to face dimensions acc. to EN 558, GR.1, full bore, ball with L- or T-bore, blow-out-proof stem, body material stainless steel (1.4408/1.4571/1.4404) or carbon steel (1.0619/1.0460), antistatic device, free of non ferrous metals, trunnion mounted ball, seats 1.4571/1.4404 hard facing metal coated, stem packing cone ring system acc. to temperature use, dynamic loaded adjustable, top flange DIN EN ISO 5211, approved by PED, certified acc. to GERMAN clean air act VDI 2440, with lever.

Marking: INTEC K411

No.	Part	Material	Material
High-temperature design			
1	body	1.0619/1.0460	1.4408/1.4571/1.4404
2	cap	1.0619/1.0460	1.4408/1.4571/1.4404
3	seal	1.4408/1.4571/1.4404 hard facing metal coated	
4	seat	1.4408/1.4571/1.4404 hard facing metal coated	
5	seat seal	Graphite	
6	follower ring	1.4571/1.4404	
7	spiral spring	Inconel X750	
8	stem	250°C 1.4462	350°C 1.4980
9	below stem bearing	E-carbon	
10	stem seal	1.4571/1.4404/Graphite	
11	upper stem bearing	E-carbon	
12	hex. nut self-locking	A2/1.4301	
13	body seal	Graphite	
14	bearing neck	1.4571/1.4404	
15	trunnion seal	Graphite	
16	bearing	E-carbon	
17+18	hex. screw	A4-70	
19	lever	1.4408/1.4308/steel zincplated	
20	stopper	1.4301	
21	allen screw	A2-70	
Fire-Safe design			
9	below stem seal	KFGN/Graphite	
	bearing	PEEK	
10	upper stem seal	KFAM/Graphite	
	Fire-Safe seal	Graphite	
11	ring	1.4571/1.4404	
	thrust washer	PEEK	
13	combined body seal	KF-Graphite	
16	bearing	PEEK	
Standard design			
5	seat seal	KF	
7	spiral spring	1.4401	
9	below stem seal	KFGN/Graphite	
	bearing	PEEK	
10	upper stem seal	KFAM/Graphite	
11	bearing	PEEK	
13	body seal	KF	
15	trunnion seal	KF	
16	bearing	PEEK	



Port Type	1	2	3	4
L				
T				

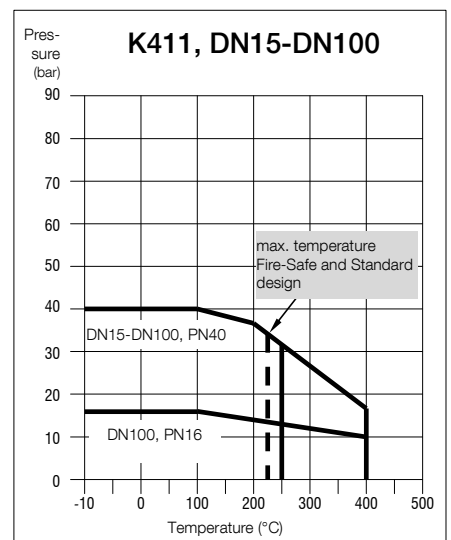

** wafer type

Ordering example:
INTEC K411, DN50, PN40, Gr.1, 1.4408

Subject to technical modification. 10/2019